



郑州高德机械设备有限公司 Gaode Equipment Co., Ltd.



地址 ADD: 郑州市金水区丰庆路 4 号院 14 号楼 9 号 邮编 P.C.:450053
No.9, Building 14, Yard No.4, Fengqing Road, Jinshui District, Zhengzhou, Henan China
网站 Web: www.gaodetec.com 邮箱 E-Mail: info@gaodetec.com
电话 TEL.:+86-371-55951210 传真 FAX:+86-371-55951210

HSC-2815 concrete spray shotcrete system

The series wet shotcrete system equipment are high-end equipment with top design and manufacture. They have multi-function and can be applied widely.

The type shotcrete equipment are suitable for bigger fracture surface, project which need big output, and tunnel construction which need high efficiency shotcrete.



Features:

1. Closed circuit hydraulic system running system, powerful chassis, wet mix braking system.
2. Four-wheel transmission, four-wheel steering, small turning radius, thus make a better operation.
3. Open-type cab, widely views, driver's seat with 180 ° rotation design, thus make the operation flexible and can drive two-way.
4. Reasonable loading design makes the equipment with bigger anti-overturning moment.
5. Full hydraulic telescope and rotate robot arm make the machine with high carrying capability, steady movement, flexible operation, no construction dead zone.
6. Electric motor and diesel two-motor drive.
7. Convey cylinder with long stroke and big cylinder diameter can reduce the abrasion of resistant ring and plate and improve the stability of concrete spraying.
8. Hydraulic drive hopper vibrator, air cooler, cable reel, accelerator pump and water pump can proof electric leakage and pollution.
9. The ratio of accelerator and concrete is in fixed and can be monitored and adjusted by touch screen and remote control.



郑州高德机械设备有限公司
Gaode Equipment Co., Ltd.



地址 ADD: 郑州市金水区丰庆路 4 号院 14 号楼 9 号 邮编 P.C.:450053
No.9, Building 14, Yard No.4, Fengqing Road, Jinshui District, Zhengzhou, Henan China
网站 Web: www.gaodetec.com 邮箱 E-Mail: info@gaodetec.com
电话 TEL: +86-371-55951210 传真 FAX: +86-371-55951210

10. All operation can be controlled by wireless remote control thus reduce labor intensity and improve working efficiency.
11. Diesel engine can make the spray arms move slowly in case the concrete solidification makes the equipment crash when electric power is off.

Technical data:

Item	unit	GSC-2815A	GSC-2815B	GSC-2815C	
Unity machine parameter	LxWxH	7800x2530x3280			
	Weight	14500	14000	12800	
Arm and Leg parameter	Arm structure	main arm rotate+ telescope (stretch out + draw back); spray arm rotate + telescope (stretch out + draw back)			
	Max. Spray height	m	15 (normal spraying height 7-10m)		
	Max. Spray width	m	2x13		
	Max. Spray depth	m	8		
	big arm pitching angle	degree	-30° ~ +60°	-30° ~ +75°	
	small arm pitching angle	degree	+60° ~ -30°	70°	
	nozzle rotary angle	degree	360°		
	nozzle swing angle	degree	240°		
	drive mode		Electric motor driven for normal work, diesel engine driven for emergency discharging and cleaning stretch out and draw back arm;		
	electric motor rated power	kW	59		
electric motor working voltage	V/Hz	380/50, 3 phase			



郑州高德机械设备有限公司
Gaode Equipment Co., Ltd.



地址 ADD: 郑州市金水区丰庆路 4 号院 14 号楼 9 号 邮编 P.C.:450053
No.9, Building 14, Yard No.4, Fengqing Road, Jinshui District, Zhengzhou, Henan China
网站 Web: www.gaodetec.com 邮箱 E-Mail: info@gaodetec.com
电话 TEL.:+86-371-55951210 传真 FAX:+86-371-55951210

	diesel engine rated power	kW	92	
Pump parameter	rated output	m ³ /h	28	
	rated reversing time	/min	23	
	system pressure	Bar	230	
	outlet pressure	Bar	70	
	convey cylinder inner diameter	mm	Φ160	
	convey cylinder stroke	mm	1000	
	nozzle diameter	mm	Φ40	Φ45
Chassis parameter	wheel base	mm	4100	
	front and rear bridge drive mode	-	4×4	
	Hydraulic oil tank capacity	L	550	
	fuel tank capacity	L	190	
	max. running speed	Km/h	22	
	max. grade ability	%	40	
	min. ground clearance	mm	450	
	min. turning radius	m	5.0	
braking distance	m	≤10		
Auxiliary system parameter	cable	m	100	
	air compressor power	kW	75	---
	air compressor output	m ³ /min	15	---
	air compressor working pressure	Bar	5	---
	additive output	L/h	800	
	additive system pressure	Bar	10	
	coagulant tank capacity	L	1000	



郑州高德机械设备有限公司

Gaode Equipment Co., Ltd.



地址 ADD: 郑州市金水区丰庆路 4 号院 14 号楼 9 号 邮编 P.C.:450053
No.9, Building 14, Yard No.4, Fengqing Road, Jinshui District, Zhengzhou, Henan China
网站 Web: www.gaodetec.com 邮箱 E-Mail: info@gaodetec.com
电话 TEL.:+86-371-55951210 传真 FAX:+86-371-55951210

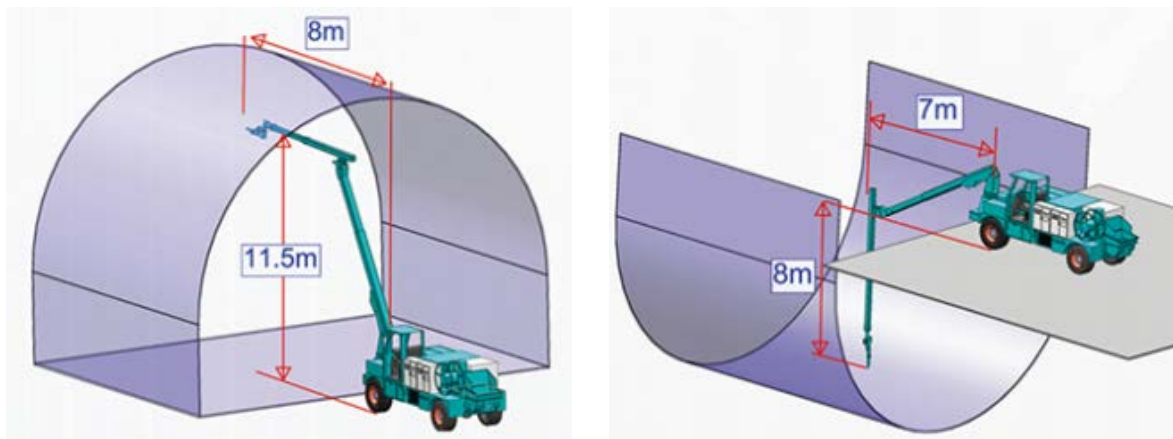
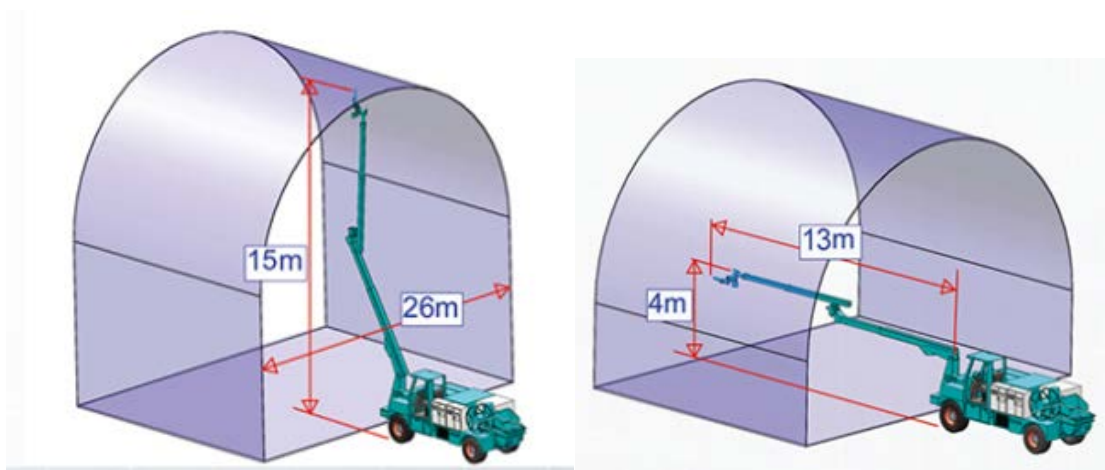



郑州高德机械设备有限公司 Gaode Equipment Co., Ltd.



地址 ADD: 郑州市金水区丰庆路4号院14号楼9号 邮编 P.C.:450053
No.9, Building 14, Yard No.4, Fengqing Road, Jinshui District, Zhengzhou, Henan China
网站 Web: www.gaodetec.com 邮箱 E-Mail: info@gaodetec.com
电话 TEL.:+86-371-55951210 传真 FAX:+86-371-55951210





郑州高德机械设备有限公司
Gaode Equipment Co., Ltd.



地址 ADD: 郑州市金水区丰庆路 4 号院 14 号楼 9 号 邮编 P.C.:450053
No.9, Building 14, Yard No.4, Fengqing Road, Jinshui District, Zhengzhou, Henan China
网站 Web: www.gaodetec.com 邮箱 E-Mail: info@gaodetec.com
电话 TEL.:+86-371-55951210 传真 FAX:+86-371-55951210

Different kinds of shotcrete machine for your option:



郑州高德机械设备有限公司
Gaode Equipment Co.,Ltd.

Add: No.9, Building 14, Yard No.4, Fengqing Road, Jinshui District, Zhengzhou, Henan China P.C. 450000

Tel: +86-371-55951210/55951660/55090762

Fax: +86-371-63526676

Email: info@gaodetec.com lena@gaodetec.com