

## GZC-15/D Conveyor and shotcrete machine combination



## ◆ Product Description

The new GZC-15/D material blower is specially designed for landscaping and soil erosion control, with simplicity and reliability as its core concept. Featuring a simplified control system and sophisticated engineering design, it is an ideal choice for bark processing, mulch laying, compost production, and soil mixing operations.

This medium-sized material blower is easy to operate and maintain, with straightforward troubleshooting, ensuring maximum uptime for critical equipment and optimal production efficiency. The product is suitable for almost all terrain conditions and can operate normally even in humid environments.

## ◆ Product Feature

1. Equipped with a 2.5 m<sup>3</sup> material hopper, which improves production efficiency and reduces operating costs.
2. Simplified control system enables easy operation, quick training and reliable performance.
3. Adopts a simplified unit design to ensure critical operating uptime, as well as convenient maintenance and troubleshooting.
4. Features an open-design rear-mounted engine for easy maintenance.
5. The whole machine is integrated on a trailer chassis for convenient transportation.
6. Designed with centralized lubrication points to enhance equipment maintainability.
7. Equipped with a water spray system for dust control in extremely dry environments or when handling highly dry materials.
8. The trailer is fitted with brake lights, marker lights, turn signals, license plate lights and reflectors, making it suitable for night-time operation.

## ◆ Product Specification

Name		Data
Model		GZC-15/D
Diesel engine	Model	YANMAR-3TNV88-BDTYC
	Power	26.9KW@3000rpm
Shotcrete machine	Output	15m <sup>3</sup> /h
	Recommended hose sizes(mm)	ID64
	Max.Aggregate size	20mm
Hopper capacity		2.5m <sup>3</sup>
Dimension		6500×2100×2330mm
Weight		3600Kg
We can also customize products according to your needs.		

## ◆ Dimension

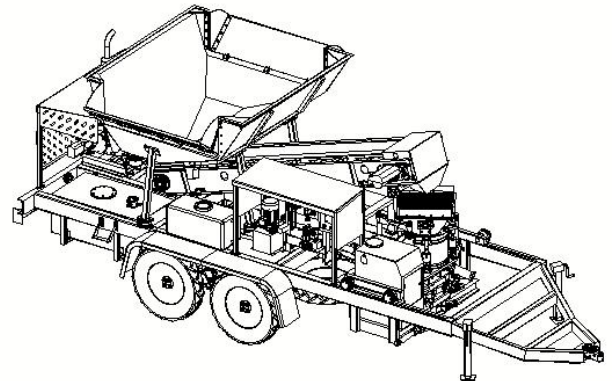
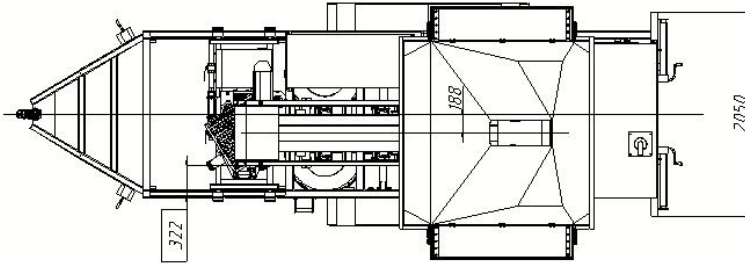
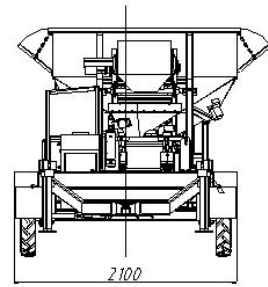
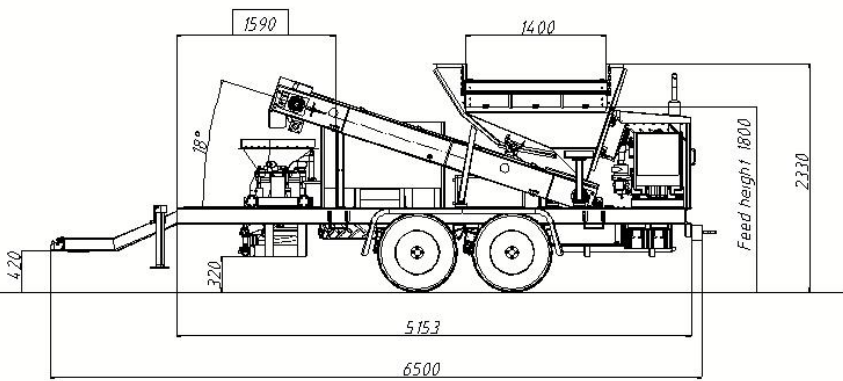

◆ Detail Part

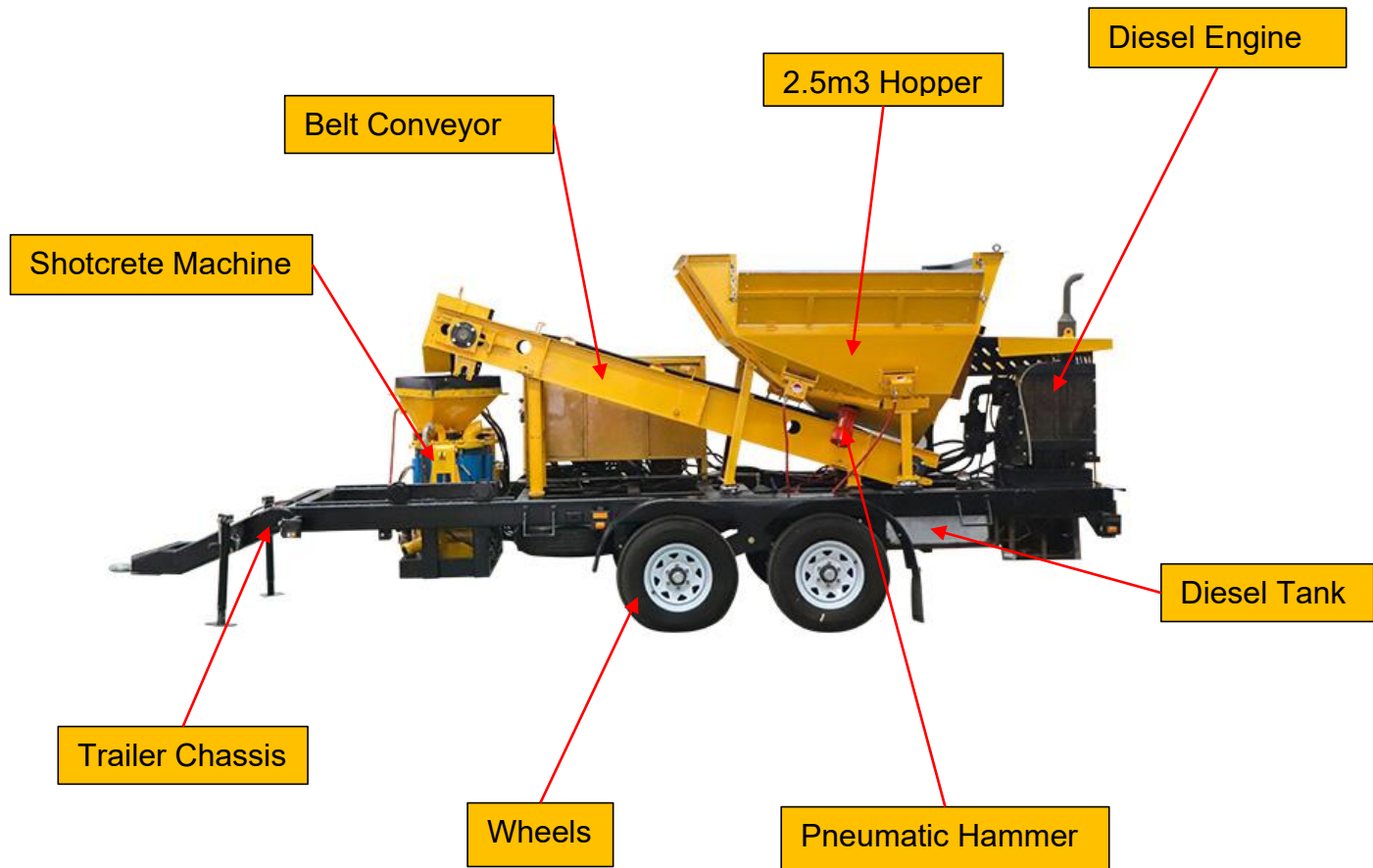





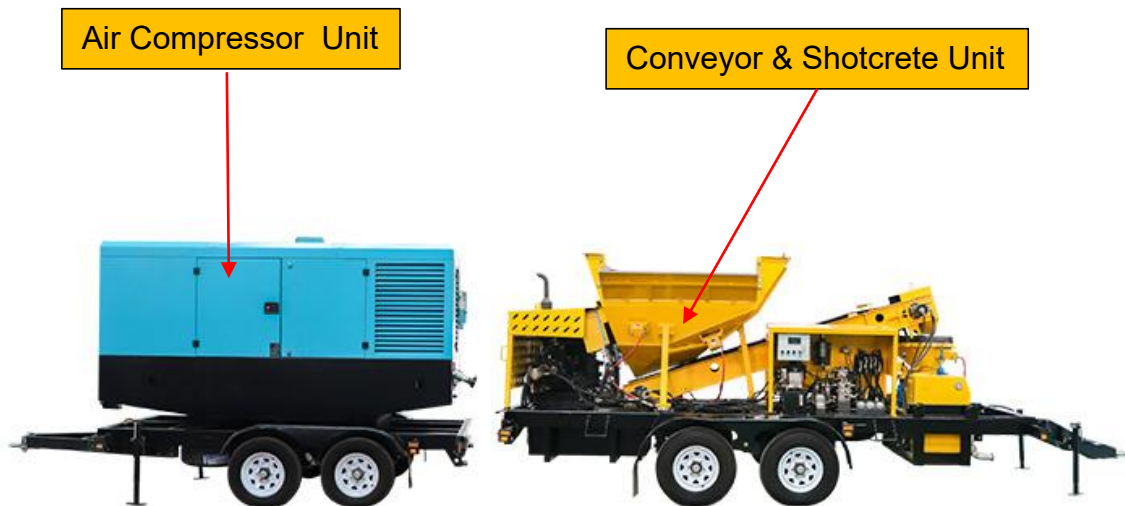

## Gaode Equipment Co., Ltd.

Add: No.9, Building 14, Yard No.4, Fengqing Road, Jinshui District,  
Zhengzhou, Henan China

Web: [www.gaodetec.com](http://www.gaodetec.com)

Email: [info@gaodetec.com](mailto:info@gaodetec.com)