

GSLC-10/D Self-leveling mortar mixing & conveying machine

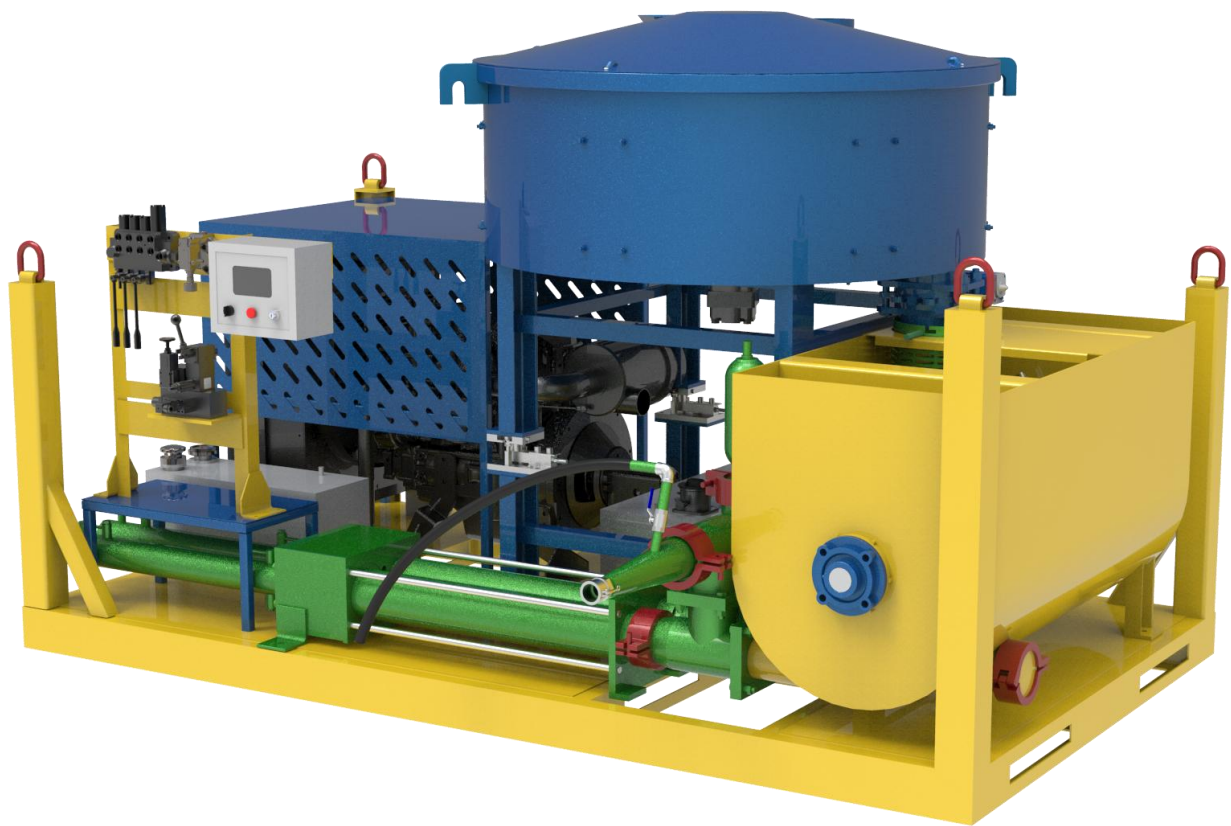

◆ Product Description

GSLC-10/D Self leveling mortar mixing conveying machine is a specialized piece of equipment integrating automatic batching, forced mixing and precise discharging. It is mainly designed for mixing various self-leveling mortars, such as gypsum-based and cement-based mortars. The diesel-powered model is equipped with its own diesel engine, independent of mains electricity, making it highly adaptable to off-grid scenarios such as field and remote construction sites.

The equipment features a compact structure, convenient mobility and simple operation, and can be flexibly configured according to construction scale. It is widely used in various building flooring applications, meeting the needs of both small-area home decoration projects and large-scale batch operations on construction sites. Backed by powerful diesel performance, it ensures efficient, stable and environmentally friendly mortar mixing.

◆ Product Feature

1. **Flexible power supply:** The diesel-powered unit is equipped with a built-in diesel engine and operates independently of mains electricity, ensuring normal operation even in remote and off-grid construction sites.
2. **Compact structure & easy transportation:** The all-in-one design features a small footprint. No disassembly is required; it can be transported by ordinary trucks or pickups, enabling fast job-site relocation and immediate operation upon arrival.
3. **Stable mixing quality:** Adopts forced mixing technology for thorough blending of powder and water, preventing agglomeration and segregation. With precise proportioning (error $\leq \pm 1\%$), it effectively guarantees the fluidity of self-leveling mortar and reduces common floor defects such as hollowing, cracking, and dusting.
4. **Labor-saving & high efficiency:** The entire process — feeding, mixing, and discharging — can be operated by a single person, greatly reducing labor requirements and physical intensity.
5. **Eco-friendly & clean:** Closed mixing and discharge design effectively controls dust, keeping the construction site clean and compliant with environmental regulations. Minimal residue and easy cleaning lower material waste and construction costs.
6. **Strong compatibility:** Compatible with gypsum-based, cement-based, and floor-heating backfill mortars without changing core components, flexibly meeting diverse construction needs.

◆ Product Specification

Name		Data
Model		GSLC-10/D
Diesel engine	Power	52-54KW
Forced Mixer	Capacity	800L
	Speed	70rpm
Agitator	Capacity	700L
	Speed	35rpm
Grout Pump	Cylinder Bore Diameter	120mm
	Stroke	850mm
	Flow@Pressure	11m ³ /h@7Mpa
	Outlet Diameter	DN38
Dimension		3050×1750×1862mm
Weight		2900Kg
We can also customize products according to your needs.		

◆ Dimension

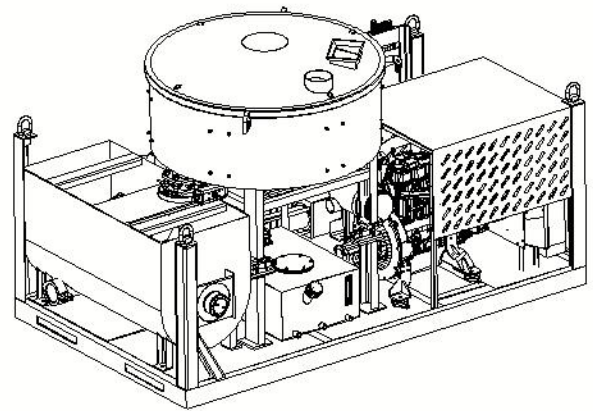
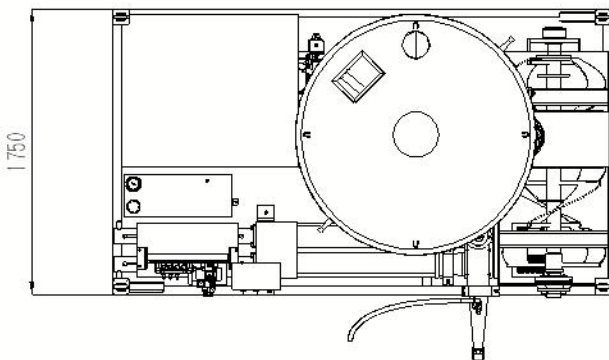
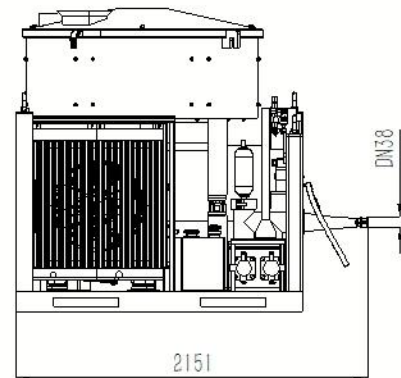
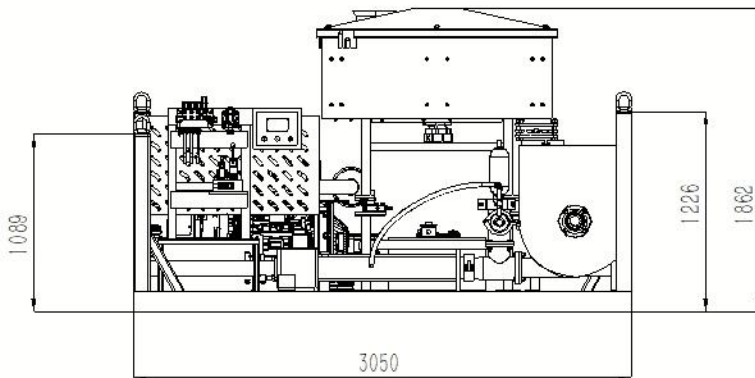

◆ Detail Part

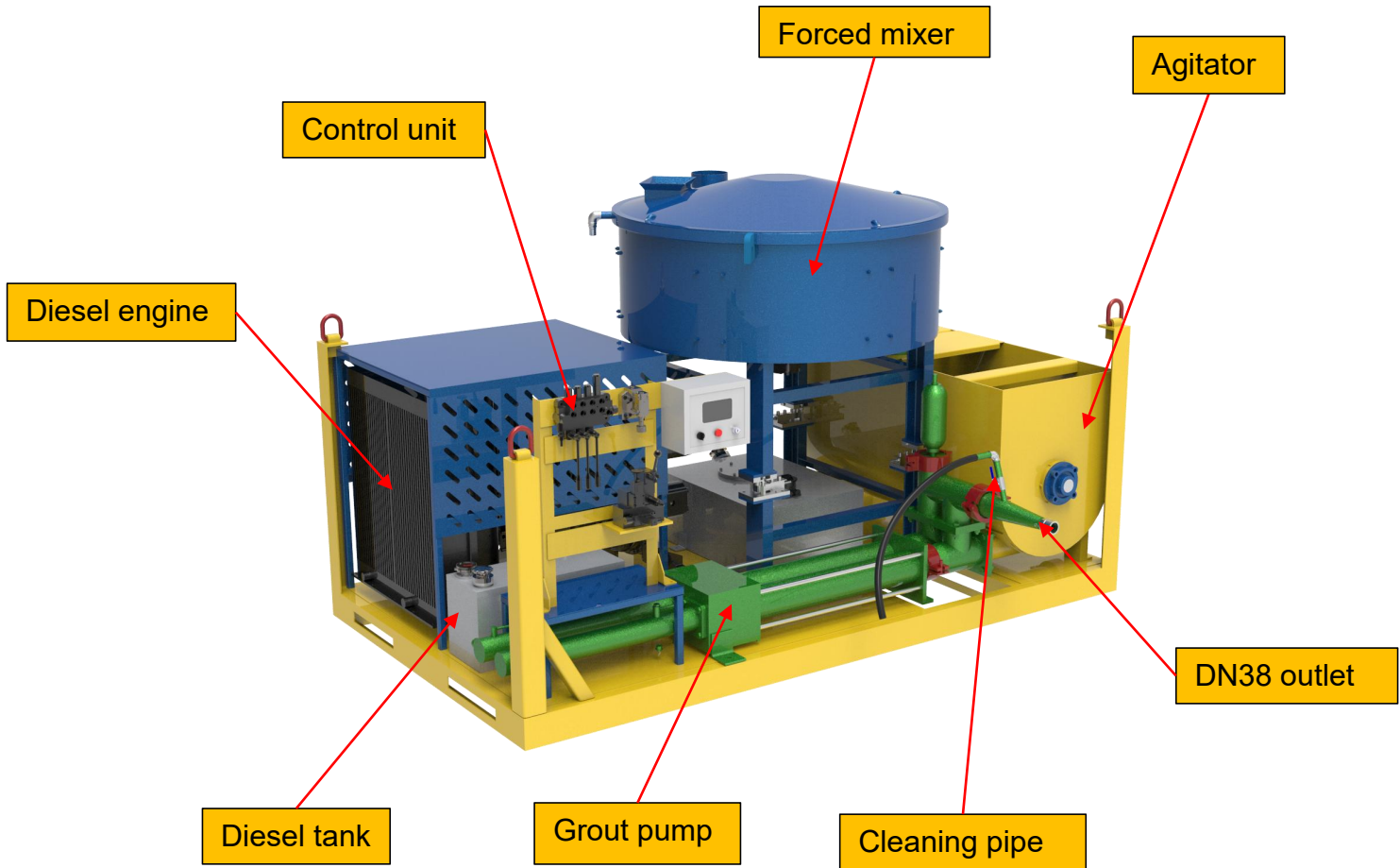

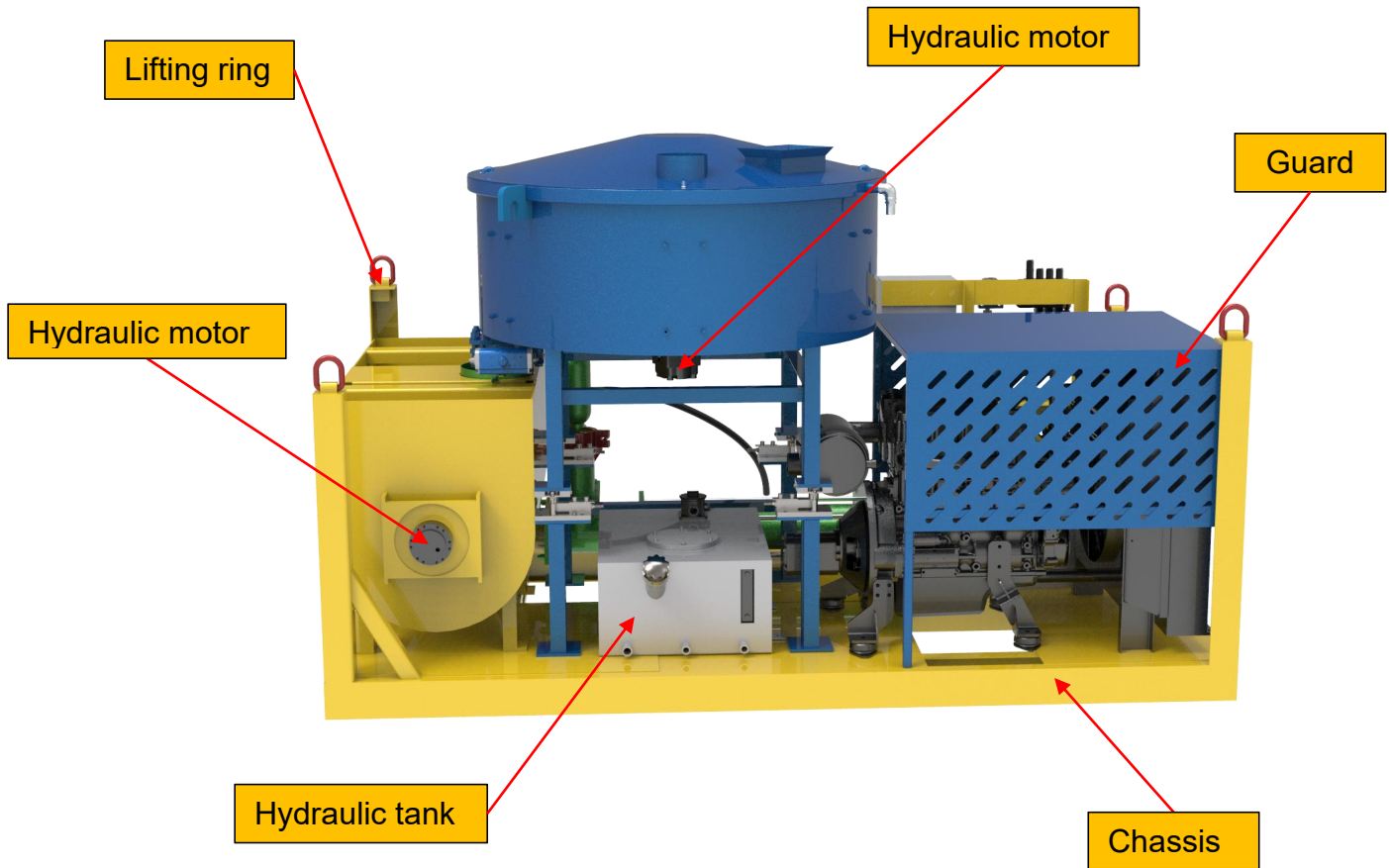

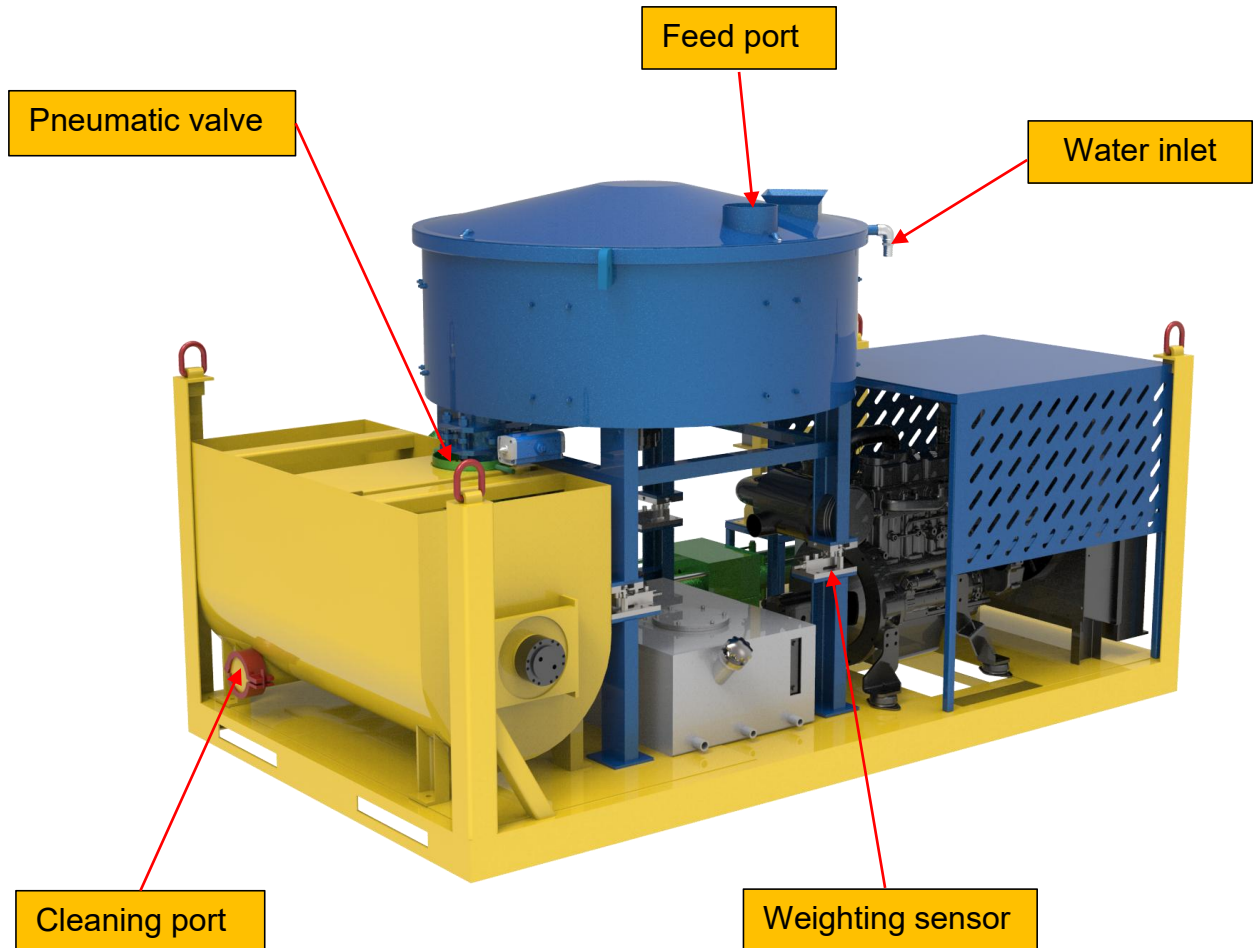

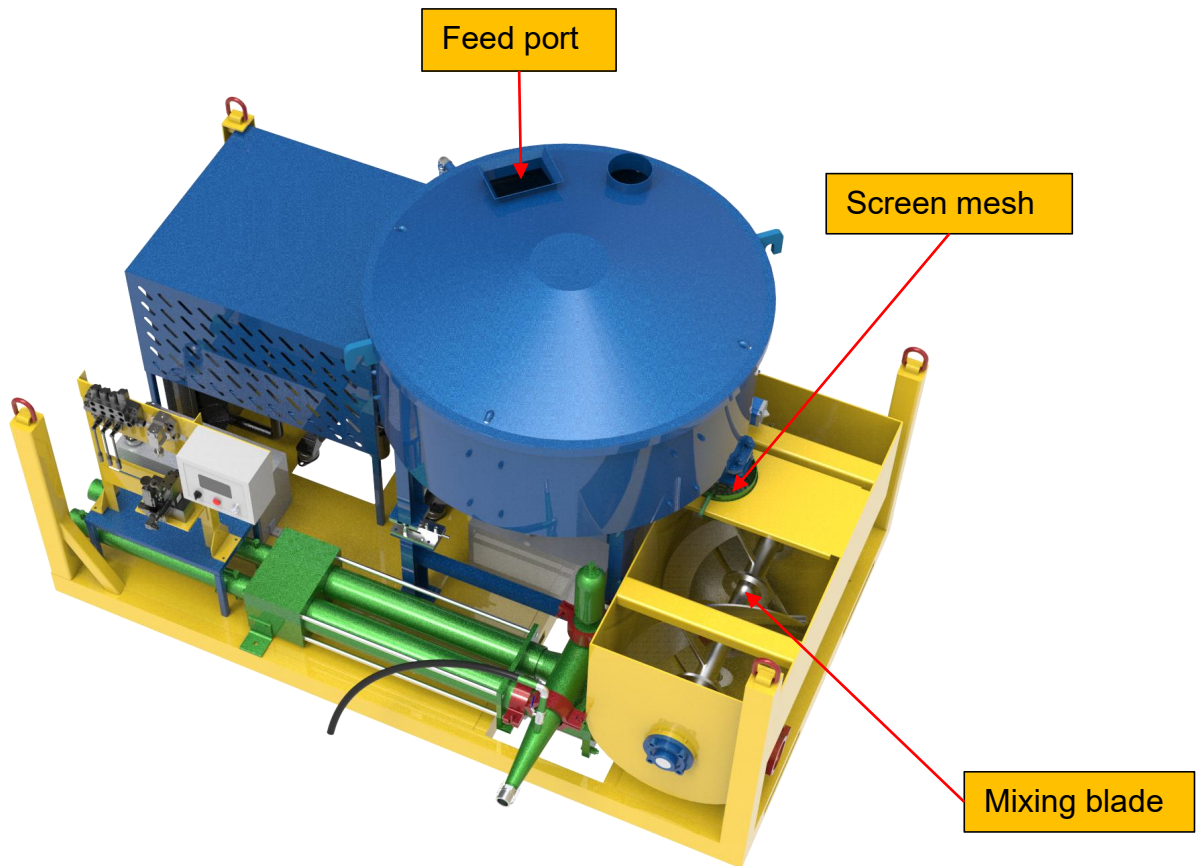

Gaode Equipment Co., Ltd.

Add: No.9, Building 14, Yard No.4, Fengqing Road, Jinshui District,
Zhengzhou, Henan China

Web: www.gaodetec.com

Email: info@gaodetec.com