

GMA850-1500A/E Grout mixing machine



◆ Product Description

The GMA850-1000A/E Grout mixer features an integrated design, with the mixer, agitator and booster pump assembled on a single base frame. It has a compact structure and is convenient for transportation. This equipment is mainly used for preparing mixtures such as cement slurry, and is widely applied in surface and underground projects, including highway, railway, hydropower, construction and mining operations..

High-speed vortex mixing technology ensures a fast and uniform mixing process, allowing water and cement to blend quickly to form a homogeneous slurry.

◆ Product Feature

1. Compact structure.
2. Simple operation and easy maintenance.
3. Less spare parts ensure low maintenance costs.
4. High speed vortex mixer ensures mixing quickly and evenly.
5. The proportion of materials in the formula can be adjusted freely.
6. It is equipped with an automatic pulping function.

◆ Product Specification

Name		Data
Model		GMA850-1500A/E
Mixer	Capacity	850L
	W/C ratio	0.5~1
	Rate Rev.	1800rpm
	Power	18.5Kw
	Production capacity	10m ³ /h
	Max pump flow rate	1200L/min@3bar
Agitator	Capacity	1500L
	Rate Rev.	39rpm
	Power	3Kw
Booster pump	Flow	700L/min
	Pressure	1Bar
	Power	3KW
Power requirements		Voltage 3 Phase 380V, 50Hz
Dimension		3350×2160×2130mm
Weight		2600Kg
We can also customize products according to your needs.		

◆ Dimension

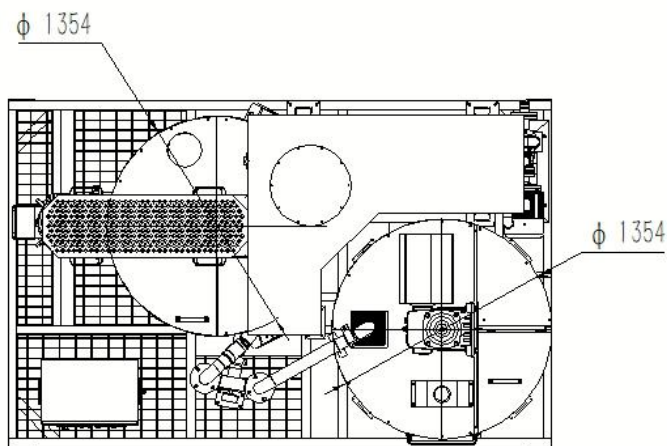
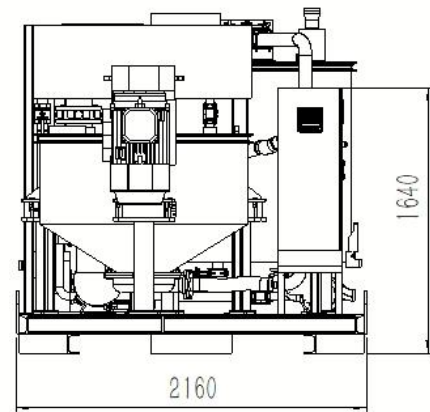
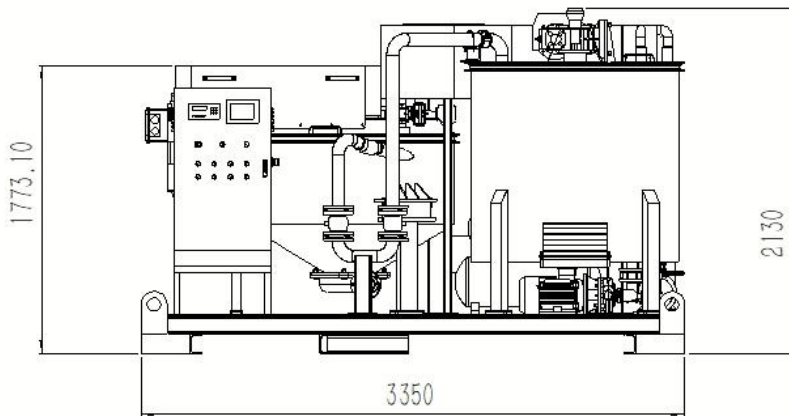

◆ Detail Part

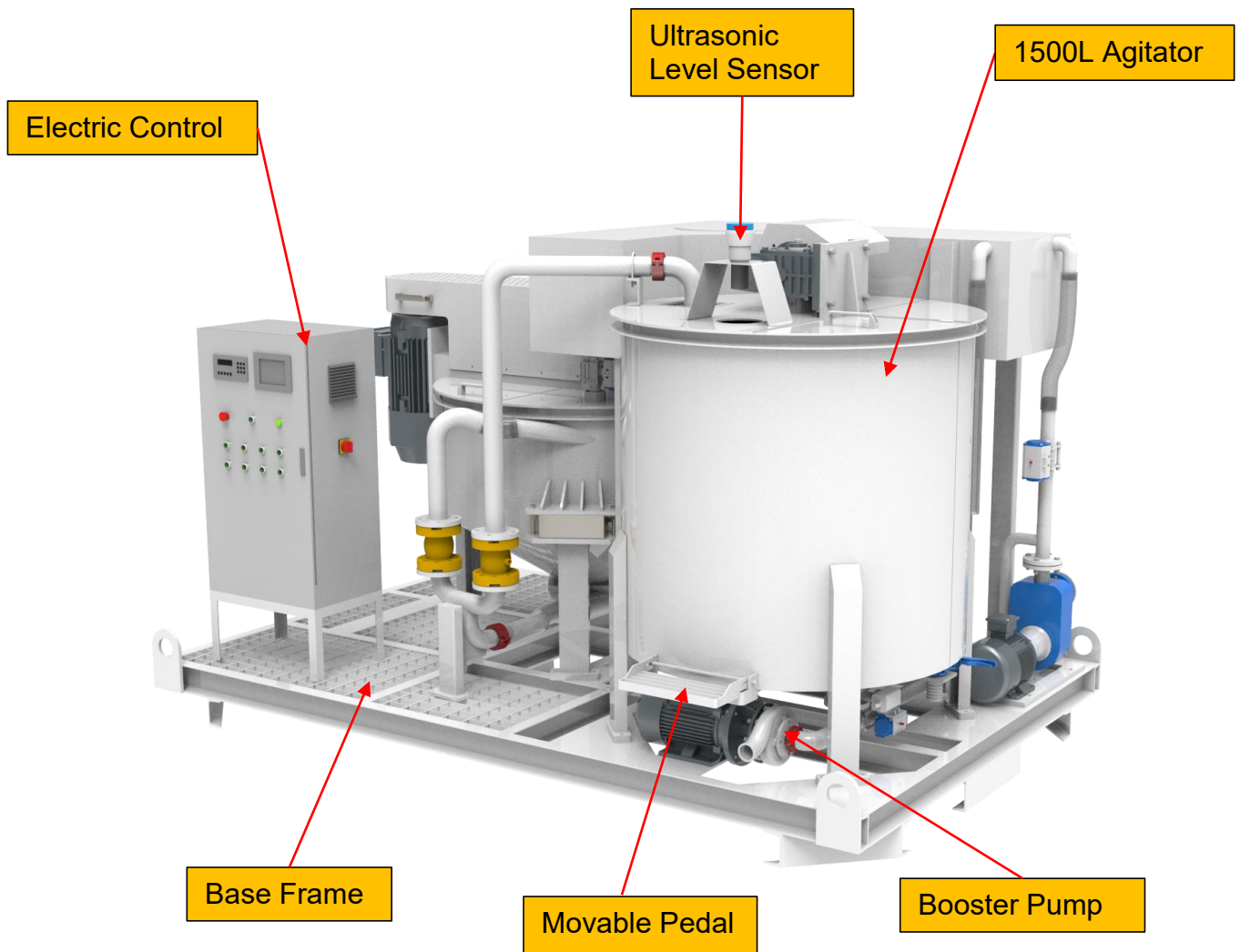

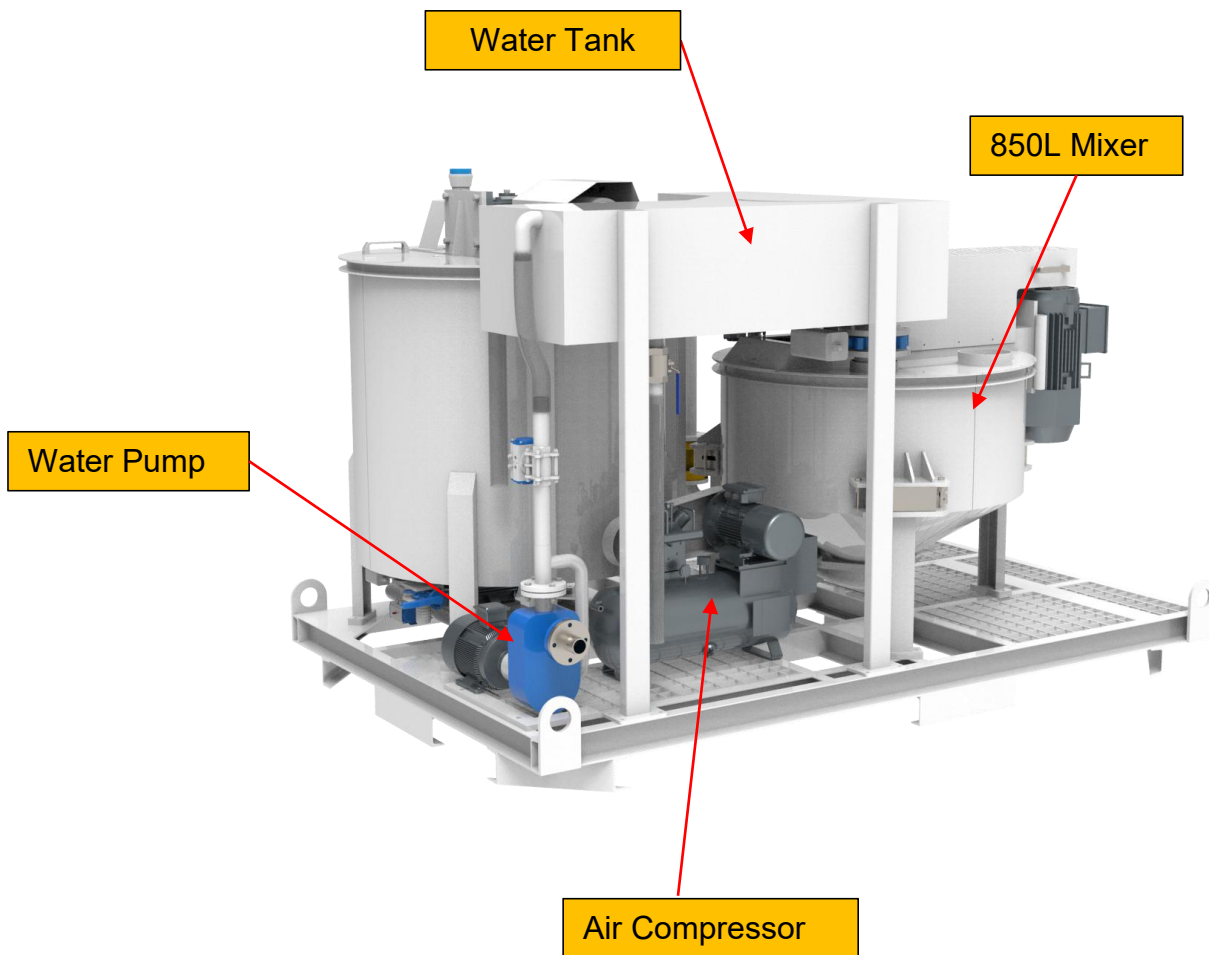

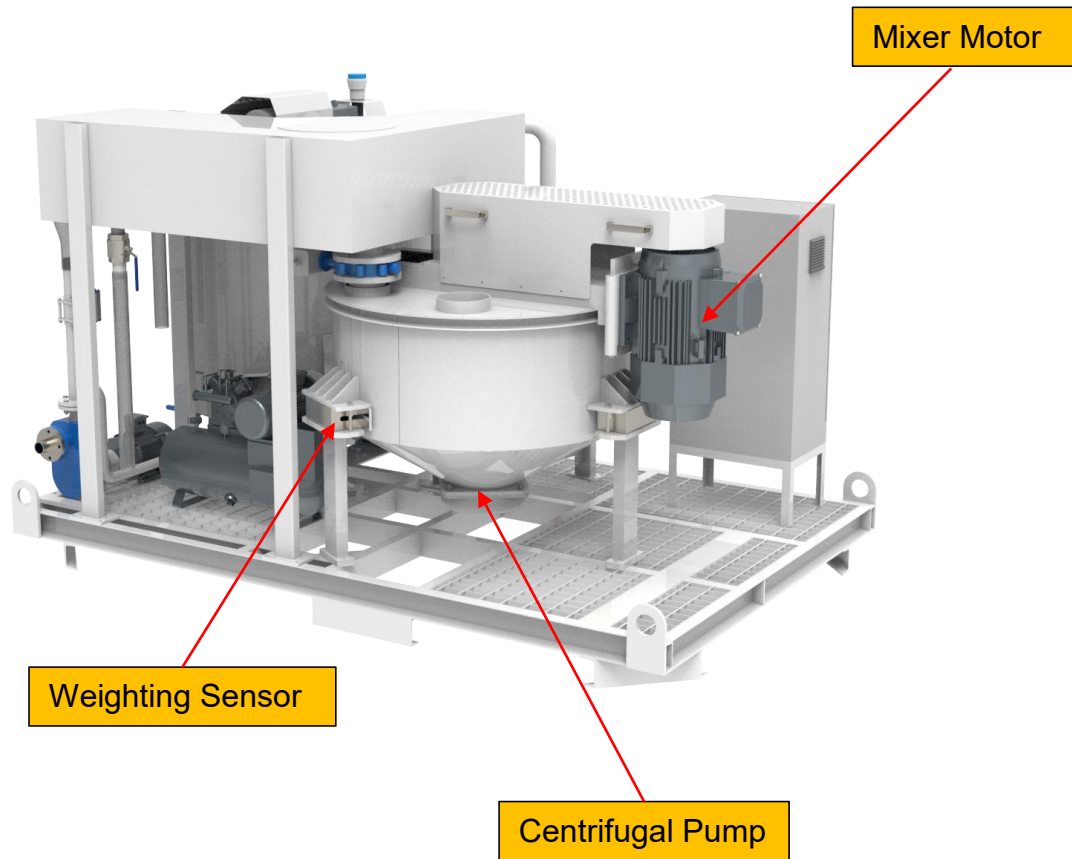

Gaode Equipment Co., Ltd.

Add: No.1307, R&D Building #5, Block B, National University Science and Technology Park of Henan Province, No.11 Changchun Road, High-Tech District, Zhengzhou City, China

Web: www.gaodetec.com

Email: info@gaodetec.com