

郑州高德机械设备有限公司

Gaode Equipment Co., Ltd.

地址 ADD: 郑州市金水区丰庆路 4 号院 14 号楼 9 号 邮编 P.C.:450053
No.9, Building 14, Yard No.4, Fengqing Road, Jinshui District, Zhengzhou, Henan China
网站 (Web) :www.gaodetec.com E-Mail: info@gaodetec.com
电话 TEL.:+86-371-55951210 传真 FAX:+86-371-55951210

DTH drill tools

- 1. DTH hammer**
- 2. DTH drill bit**
- 3. Casting Drill System**

郑州高德机械设备有限公司

Gaode Equipment Co., Ltd.

地址 ADD: 郑州市金水区丰庆路 4 号院 14 号楼 9 号 邮编 P.C.:450053
No.9, Building 14, Yard No.4, Fengqing Road, Jinshui District, Zhengzhou, Henan China
网站 (Web) :www.gaodetec.com E-Mail: info@gaodetec.com
电话 TEL.:+86-371-55951210 传真 FAX:+86-371-55951210

DTH High Air Pressure Hammer

Feature:

1. In order to increase working life of the piston case when drilling very abrasive rocks, the driver sub is designed to be made up of three pieces and only the wear-proof casing need to be replaced timely.
2. Heat treated piston and internal cylinder guiding system are reasonably structured to achieve the highest efficiency and the largest impacting power. The penetration speed is 10%-30% faster than other products of the same type.
3. TND optimized structure design: Fewer air holes on internal cylinder, higher Stiffness of air slot
4. The multiple threads are CNC machined to achieve high accuracy, making the bit easy and smooth to get assembled.
Driver sub is heat treated to achieve better abrasiveness and longer life.
5. Hammer front structure design: when pulling out the hammer, the last impact of the piston would fall on the step of piston case, ensuring the safety of the driver sub spline and the retainer ring.
6. Piston case: Using superior alloy steel, even better reliability and longer life after heat treatment.
7. Internal parts are tightly assembled to avoid interactive wear and hammer's reliability is increased.
8. Standard API Thread
9. Top sub with cement carbide button (Alternative).

郑州高德机械设备有限公司

Gaode Equipment Co., Ltd.

地址 ADD: 郑州市金水区丰庆路 4 号院 14 号楼 9 号

邮编 P.C.:450053

No.9, Building 14, Yard No.4, Fengqing Road, Jinshui District, Zhengzhou, Henan China

网站 (Web) :www.gaodetec.com E-Mail: info@gaodetec.com

电话 TEL.:+86-371-55951210

传真 FAX:+86-371-55951210

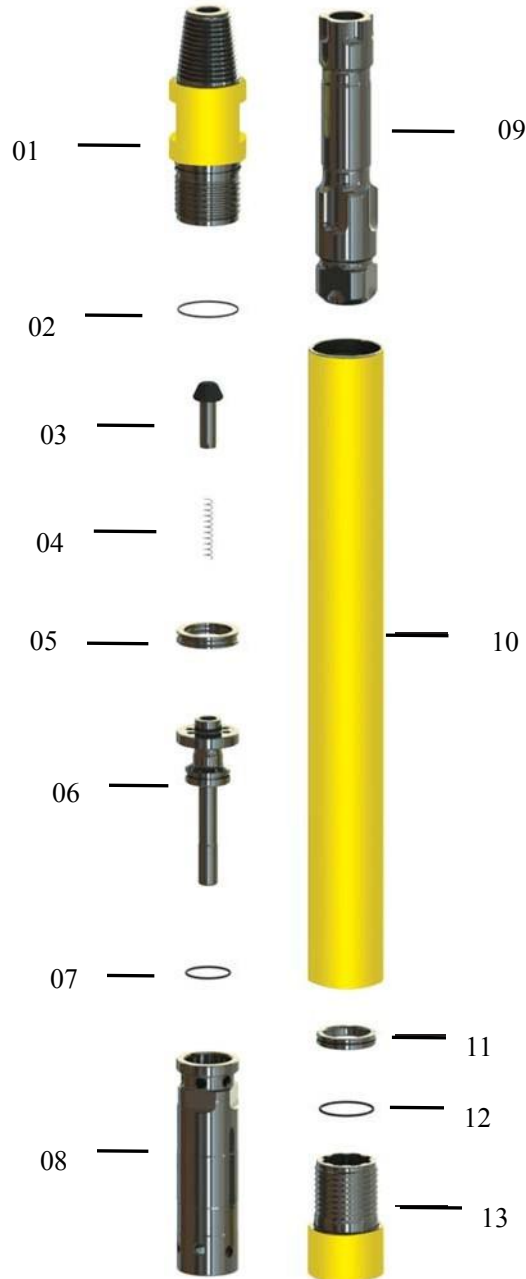

High Pressure Hammer with foot valve

郑州高德机械设备有限公司

Gaode Equipment Co., Ltd.

地址 ADD: 郑州市金水区丰庆路 4 号院 14 号楼 9 号 邮编 P.C.:450053
 No.9, Building 14, Yard No.4, Fengqing Road, Jinshui District, Zhengzhou, Henan China
 网站 (Web) :www.gaodetec.com E-Mail: info@gaodetec.com
 电话 TEL.:+86-371-55951210 传真 FAX:+86-371-55951210

No.	Replancement Parts	Weight (kg)	Part No.
01	Top Sub API REG	5.08	TND-HJT-3.5
02	O-Ring	0.01	O-HJT3.5
03	Check Valve Dart	0.14	TND-NZF-3.5
04	Spring	0.02	TH-3.5
05	Steel Washer	0.1	TND-KZD-3.5
06	Rigid Valve	0.82	TND-PQG-3.5
07	O-ring	0.01	O-PQG-3.5
08	Internal Cylinder	1.2	TND-NG-3.5
09	Piston	5.08	TND-HS-IR3.5
10	Piston Case	8.24	TND-WTG-IR3.5
11	Bit Retainer Ring	0.12	KH-3.5
12	O-ring	0.01	O-KH-3.5
13	Driver Sub	1.79	TND-QJT-3.5
14	Sealing Kit	0.03	SK-IR3.5
Bit Shank		 <p>180</p> <p>八花键 8 splines</p>	
DHD3.5			
Bit Diameter			
90mm, 100mm, 105mm			

Weight (kg)	Outside Diameter(mm)	Hammer Length without bit (mm)		
22.62	80	808		
Hole Range	Working pressure	Air consumption (m3/min)		
mm	Bar	10bar	18bar	24bar
90~105	8~30	4.5	9.5	12.5

郑州高德机械设备有限公司

Gaode Equipment Co., Ltd.

地址 ADD: 郑州市金水区丰庆路 4 号院 14 号楼 9 号

邮编 P.C.:450053

No.9, Building 14, Yard No.4, Fengqing Road, Jinshui District, Zhengzhou, Henan China

网站 (Web) :www.gaodetec.com E-Mail: info@gaodetec.com

电话 TEL.:+86-371-55951210

传真 FAX:+86-371-55951210

Hammer Model	Hole Range (mm)	Outside diameter (mm)	Hammer length without bit (mm)
TND-IR3.5	90~105	80	808
TND-IR340	105~130	99	881
TND-QL40	105~130	99	952
TND-SD4	105~130	99	932
TND-IR350	133~152	126	992
TND-QL50	133~152	126	972
TND-SD5	133~152	126	1043
TND-IR360	152~254	144	1135
TND-QL60	152~254	144	1080
TND-SD6	152~254	144	1150
TND-IR380	194~305	182	1228
TND-QL80	194~305	182	1211
TND-SD8	152~254	182	1199

郑州高德机械设备有限公司

Gaode Equipment Co., Ltd.

地址 ADD: 郑州市金水区丰庆路 4 号院 14 号楼 9 号

邮编 P.C.:450053

No.9, Building 14, Yard No.4, Fengqing Road, Jinshui District, Zhengzhou, Henan China

网站 (Web) :www.gaodetec.com E-Mail: info@gaodetec.com

电话 TEL.:+86-371-55951210

传真 FAX:+86-371-55951210

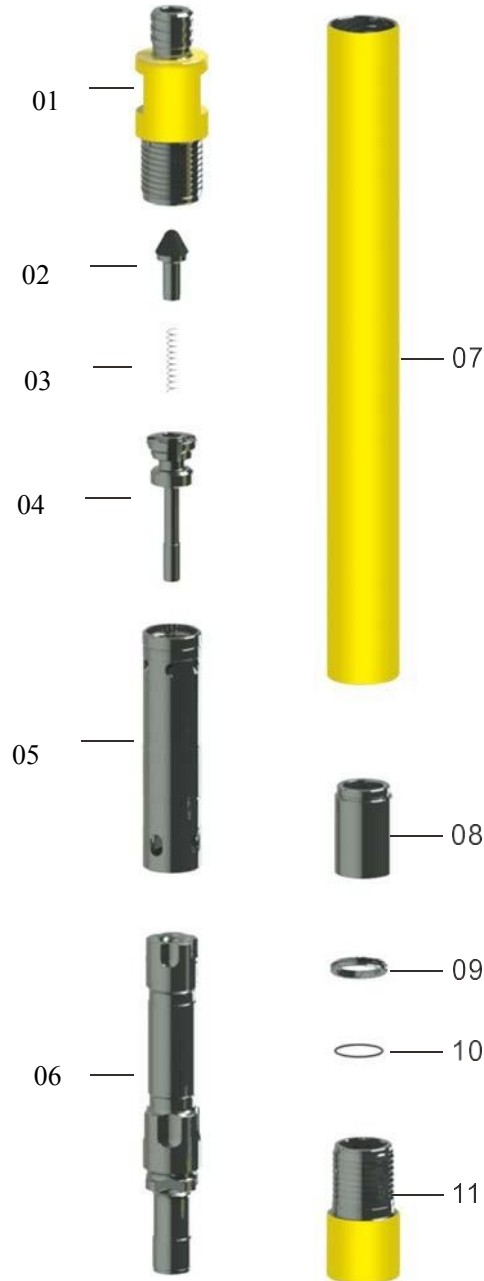

郑州高德机械设备有限公司

Gaode Equipment Co., Ltd.

地址 ADD: 郑州市金水区丰庆路 4 号院 14 号楼 9 号 邮编 P.C.:450053
 No.9, Building 14, Yard No.4, Fengqing Road, Jinshui District, Zhengzhou, Henan China
 网站 (Web) :www.gaodetec.com E-Mail: info@gaodetec.com
 电话 TEL.:+86-371-55951210 传真 FAX:+86-371-55951210

High Pressure Hammer without foot valve

No.	Replantcement Parts	Weight (kg)	Part No.
01	Top Sub API REG	3.34	TND-HJT-2.5
02	Check Valve Dart	0.10	TND-NZF-2.5
03	Spring	0.02	TH-2.5
04	Rigid Valve	0.82	TND-NG-2.5
05	Internal Cylinder	0.97	TND-HS-2.5N
06	Piston	4.00	TND-HS-2.5N
07	Piston Case	5.96	TND-WTG-2.5N
08	Guide Sleeve	0.55	TND-DXT-2.5N
09	Bit Retainer Ring	0.06	TND-KH-2.5
10	O-ring	0.01	O-KH-2.5
11	Driver Sub	1.74	TND-QJT-2.5
12	Sealing Kit	0.01	SK-2.5N
Bit Shank			
CWG76N			
Bit Diameter			
78mm			

Weight (kg)	Outside Diameter(mm)	Hammer Length without bit (mm)		
17.5	70	806		
Hole Range	Working pressure	Air consumption (m3/min)		
mm	Bar	10bar	18bar	24bar
76~80	8~24	2	4	6

郑州高德机械设备有限公司

Gaode Equipment Co., Ltd.

地址 ADD: 郑州市金水区丰庆路 4 号院 14 号楼 9 号

邮编 P.C.:450053

No.9, Building 14, Yard No.4, Fengqing Road, Jinshui District, Zhengzhou, Henan China

网站 (Web) :www.gaodetec.com E-Mail: info@gaodetec.com

电话 TEL.:+86-371-55951210

传真 FAX:+86-371-55951210

Hammer Model	Hole Range (mm)	Outside diameter (mm)	Hammer length without bit (mm)
TND-2.5N	76~80	70	806
TND-3.5N	90~105	80	863
TND-M30	90~105	80	909
TND-340N	105~130	99	936
TND-M40	105~130	99	955
TND-350N	133~152	126	1045
TND-M50	133~152	126	1045
TND-QL50N	133~152	126	1025
TND-360N	152~254	144	1187
TND-M60	152~254	144	1108
TND-QL60N	152~254	144	1131
TND-380N	194~305	182	1318
TND-M80	194~305	182	1298
TND-QL80N	194~305	182	1300

DTH High Pressure Drill Bit

Version: July.2016

Copyright@Gaode Equipment Co., Ltd.

郑州高德机械设备有限公司

Gaode Equipment Co., Ltd.

地址 ADD: 郑州市金水区丰庆路 4 号院 14 号楼 9 号 邮编 P.C.:450053
No.9, Building 14, Yard No.4, Fengqing Road, Jinshui District, Zhengzhou, Henan China
网站 (Web) :www.gaodetec.com E-Mail: info@gaodetec.com
电话 TEL.:+86-371-55951210 传真 FAX:+86-371-55951210

DTH bit is our company main product. After many years search, we have rich experience in development and manufacture which adopted high-quality raw materials, advanced craft technology and passed through strictly inspection, manufacturing high quality products.

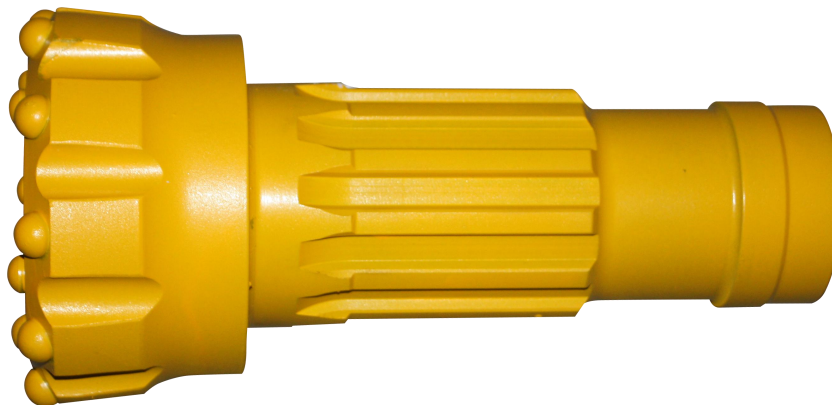

Feature:

1. High and low air pressure down-the-hole drill bits
2. Low air pressure hole Dia.: 65-220mm
3. High air pressure hole Dia.: 85-305mm
4. Face type: concave/convex/flat
5. Bit Shank Series: COP, DHD, QL, SD, Mission, TD, BR etc.
6. Button Shape: Dome/Spherical, Ballistic

Bit head design and selection

郑州高德机械设备有限公司

Gaode Equipment Co., Ltd.

地址 ADD: 郑州市金水区丰庆路 4 号院 14 号楼 9 号





邮编 P.C.:450053

No.9, Building 14, Yard No.4, Fengqing Road, Jinshui District, Zhengzhou, Henan China

网站 (Web) :www.gaodetec.com E-Mail: info@gaodetec.com

电话 TEL.:+86-371-55951210

传真 FAX:+86-371-55951210

Bit Head Face Type		Application
	Flat Front Spherical	For drilling in hard and abrasive rock
	Flat Front Spherical + Ballistic	For drilling in medium-hard to hard and moderately abrasive rock.
	Convex Front Spherical + Ballistic	For drilling in For drilling in medium-hard to hard and moderately abrasive rock.
	Convex Front Ballistic	For drilling at high penetration rates in nonabrasive rock.
	Concave front Spherical	For drilling in medium-hard, minimum hole deviation control.

郑州高德机械设备有限公司

Gaode Equipment Co., Ltd.

地址 ADD: 郑州市金水区丰庆路 4 号院 14 号楼 9 号

邮编 P.C.:450053

No.9, Building 14, Yard No.4, Fengqing Road, Jinshui District, Zhengzhou, Henan China

网站 (Web) :www.gaodetec.com E-Mail: info@gaodetec.com

电话 TEL.:+86-371-55951210

传真 FAX:+86-371-55951210

Bit Shank Series	Bit Size (mm)	Splines Quantity	Matchable Hammer Model
DHD3.5	90; 110;105	8	TND-IR3.5
DHD340A	108; 115; 121; 127; 130	8	TND-IR340
QL40	108; 115; 121; 127; 130	10	TND-QL40
SD4	108; 115; 121; 127; 130	8	TND-SD4
DHD350R	140; 148; 152	8	TND-IR350
QL50	140; 148; 152	12	TND-QL50
SD5	140; 148; 152	8	TND-SD5
DHD360	155; 159; 165; 178; 190; 203	8	TND-IR360
QL60	155; 159; 165; 178; 190; 203	12	TND-QL60
SD6	155; 159; 165; 178; 190; 203	8	TND-SD6
DHD380	194; 203; 216; 219;	10	TND-IR380

郑州高德机械设备有限公司

Gaode Equipment Co., Ltd.

地址 ADD: 郑州市金水区丰庆路 4 号院 14 号楼 9 号

邮编 P.C.:450053

No.9, Building 14, Yard No.4, Fengqing Road, Jinshui District, Zhengzhou, Henan China

网站 (Web) :www.gaodetec.com E-Mail: info@gaodetec.com

电话 TEL.:+86-371-55951210

传真 FAX:+86-371-55951210

	222; 254; 270; 305		
QL80	194; 203; 216; 219; 222; 254; 270; 305	16	TND-QL80
SD8	194; 203; 216; 219; 222; 254; 270; 305	8	TND-SD8

郑州高德机械设备有限公司

Gaode Equipment Co., Ltd.

地址 ADD: 郑州市金水区丰庆路 4 号院 14 号楼 9 号 邮编 P.C.:450053
No.9, Building 14, Yard No.4, Fengqing Road, Jinshui District, Zhengzhou, Henan China
网站 (Web) :www.gaodetec.com E-Mail: info@gaodetec.com
电话 TEL.:+86-371-55951210 传真 FAX:+86-371-55951210

Eccentric Drilling Tools with casing tube

Eccentric casing drilling system is today's preferred method for drilling in difficult ground conditions, for example, where there are boulders or loose formations.

Eccentric casing drilling system is the most economical solutions because its ingenious reaming wing the bit is retrievable can be used at the next hole. This is particularly design for shallow holes, as is often the case in water well drilling, geothermal wells and for shallow micro-piling work. EDS is ideal for short holes in consolidated overburden.

The component of Eccentric system consists of Pilot bits, Reamer bits, Guide device and casing shoe.

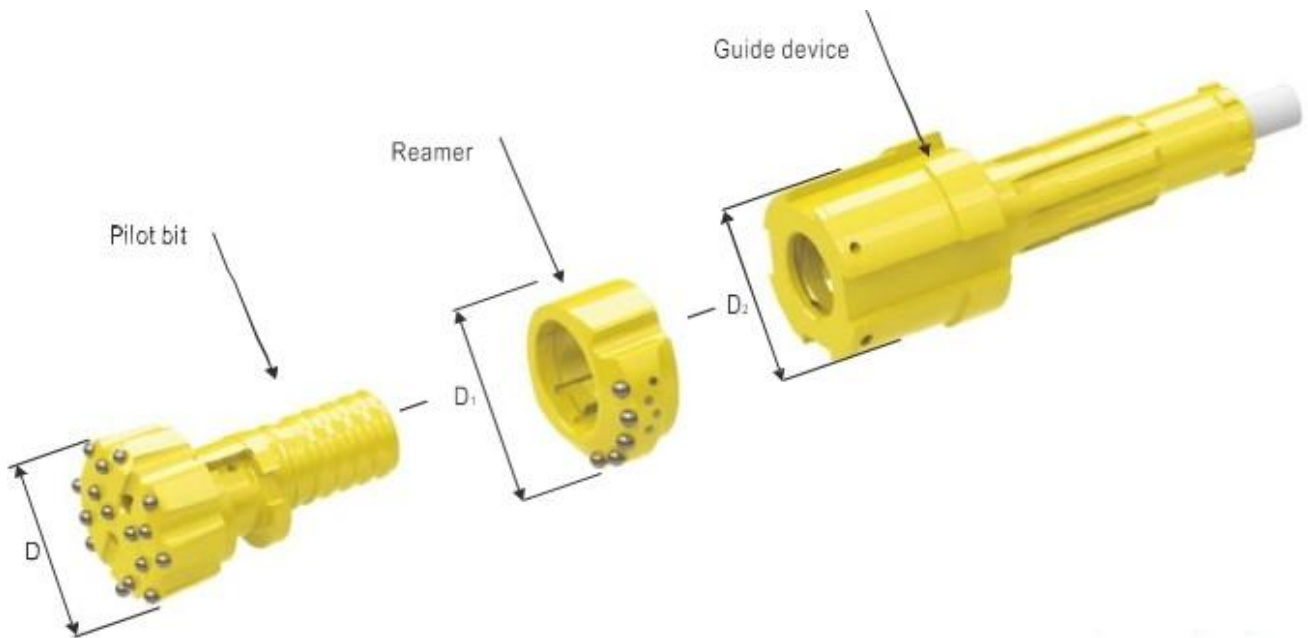

郑州高德机械设备有限公司

Gaode Equipment Co., Ltd.

地址 ADD: 郑州市金水区丰庆路 4 号院 14 号楼 9 号 邮编 P.C.:450053
 No.9, Building 14, Yard No.4, Fengqing Road, Jinshui District, Zhengzhou, Henan China
 网站 (Web) :www.gaodetec.com E-Mail: info@gaodetec.com
 电话 TEL.:+86-371-55951210 传真 FAX:+86-371-55951210

Eccentric Drilling tools with casing tube step-by-step

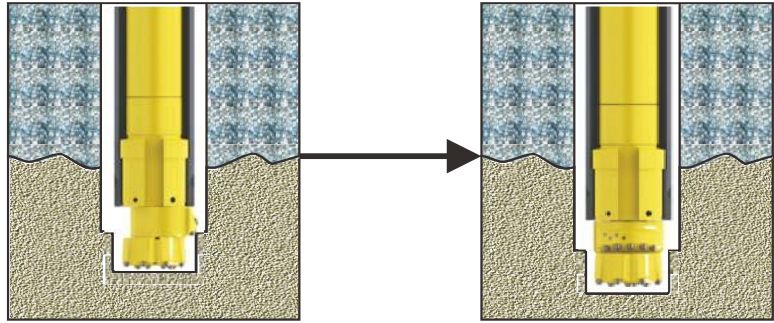
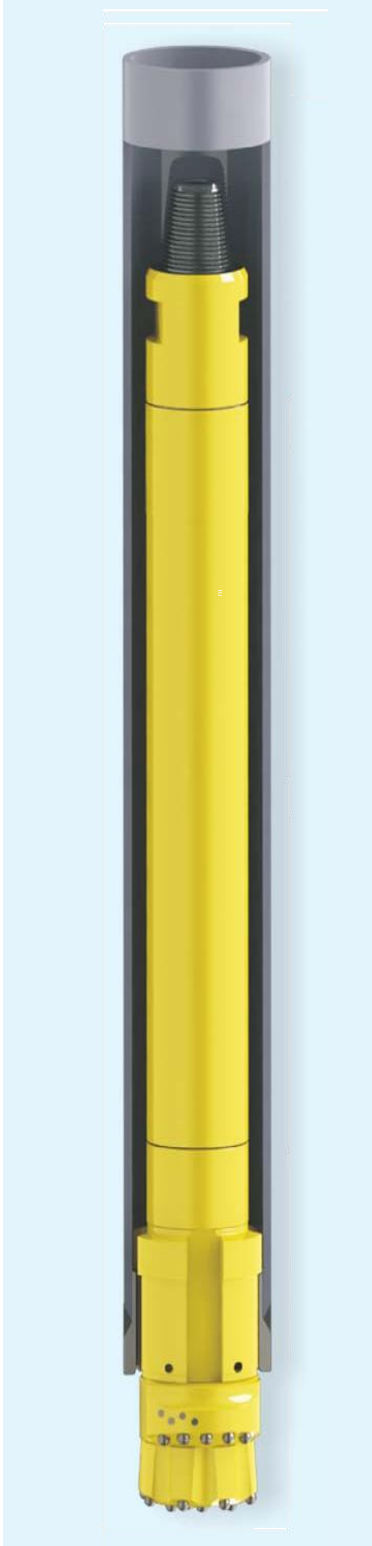

1. When drilling, the PGZ reamer swings out and drills a hole wide enough for the casing tube to slide down behind the reamer
2. When required depth is reached, the drill is reversed and the reamer swings in, allowing the bit to pass through the casing.

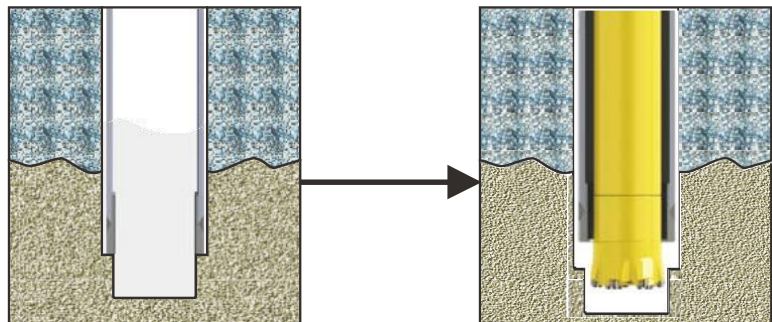

4. Casing tube is pulled out directly or fixed at the bottom of the hole by means of cement grout or other agglutinant.
5. Drilling continues to the desired depth using conventional DTH equipment.

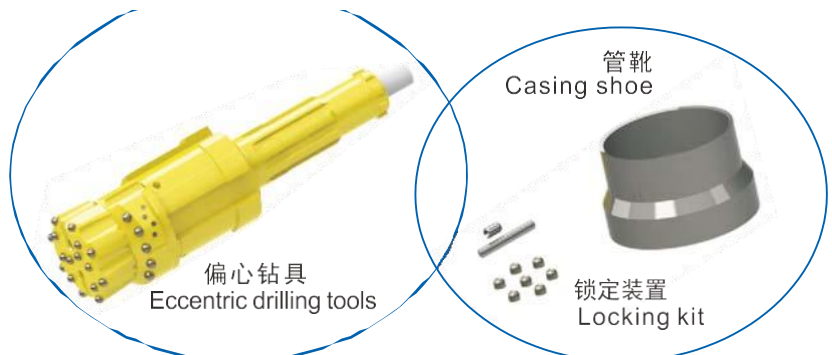

郑州高德机械设备有限公司

Gaode Equipment Co., Ltd.

地址 ADD: 郑州市金水区丰庆路 4 号院 14 号楼 9 号

邮编 P.C.:450053

No.9, Building 14, Yard No.4, Fengqing Road, Jinshui District, Zhengzhou, Henan China

网站 (Web) :www.gaodetec.com E-Mail: info@gaodetec.com

电话 TEL.:+86-371-55951210

传真 FAX:+86-371-55951210

总成代号 Assembly Code	套管 Casing tube		偏心扩 孔直径 Max Reaming dia. D ₁ (mm)	导向钻头 直径 Pilot bit dia. D (mm)	导向器 Guide device D ₂ (mm)	尾柄型号 shank style
	外径 Outside dia. (mm)	最大壁厚 Wall thickness (mm)				
PGZ82-3.5-108/6	108	6	116	82	94	DHD3.5
PGZ90-3.5-114/6	114	6	123	90	100	DHD3.5
PGZ115-340-142/7	142	7	151	115	126	DHD340A
PGZ115-340-146/7.5	146	7.5	155	115	128	DHD340A
PGZ140-350-168/8	168	8	189	140	149	DHD350R
PGZ140-350-178/9	178	9	192	144	156	DHD350R
PGZ149-350-183/10	183	10	197	149	161	DHD350R
PGZ165-360-195/6.5	195	6.5	211	165	179	DHD360
PGZ180-360-219/12.5	219	12.5	232	179	191	DHD360
PGZ190-360-219/7	219	7	236	190	203	DHD360
PGZ230-380-273/11.5	273	11.5	286	228	247	DHD380
PGZ240-380-273/6.5	273	6.5	308	240	257	DHD380

(The data of all the performance parameters are based on ideal working conditions, the company reserves the right to modify parameters)

(本资料所有性能参数均基于理想的工作条件, 公司保留修改参数的权利)